

500W+500W WATT

Mini Redundant Power Supply for IPC-Computer

PCHP500R2-I

GENERAL SPECIFICATION

This product of **Hot-Swap & Power Sharing** redundant Power supply provides increased reliability when integrated a variety of Systems. It is ideally suited to telecommunications and Industrial system, as well as a variety of other applications where system never shut down. i.e. Zero down time.

This redundant power supply consists of

- One of passive Back plane.
- One of exothermal enclosure.
- Two of compact size power modules with Hot-Pluggable connector made by Germany.
- Screw package.
- Alarm reset bottom.



FEATURE

- **Dual AC IN-Put design: AC-1 be Master source, AC-2 be second source.**
- **Dual AC PATENT: USA, Germany, Taiwan,**
- PS/2 Size design.
- Hot-Swappable & Power Sharing capability.
- Auto Select AC input.

1) INPUT

Description	
Input Voltage	95~132VAC /185~264VAC User selectable 50 to 60 Hz.
Efficiency	>=66%at full load. (Normal Line)

2) OUTPUT

***Hold-Up Time:** 16ms at maximum load & normal input voltage.

Voltage	Output-1	Output-2	Output-3	Output-4	Output-5	Output-6
	+5V DC	+3.3V DC	+12V DC	-5V DC	-12V DC	+5V S/B
Maximum Load	42A	24A	28A (Peak 30A)	0.5A	0.8A	2.0A

Note:

- The combined total power from +5V and +3.3V shall not exceed 220W.
- The combined total power from +5V and +12V & +3.3V shall not exceed 475W
- Noise Test – Noise bandwidth is from DC to 20 MHz.
- Ripple frequencies greater than 1MHz shall be attenuated by the measurement System.
- Add 0.1uF/10uF capacitor at output connector terminals for ripple and noise measurements.

3) PS-ON :

Remote On/Off Control:

When PS-ON is pulled to TTL Low, the DC output is to be enabled.

When PS-OFF is pulled to TTL HIGH, the DC output is to be disabled.

4) PW-OK

PW-OK is power good signal and should be asserted high by the power supply to indicate that +5VDC and +3.3VDC output are above the under voltage thresholds of the power supply TTL. compatible signal out with 100ms to 500ms.

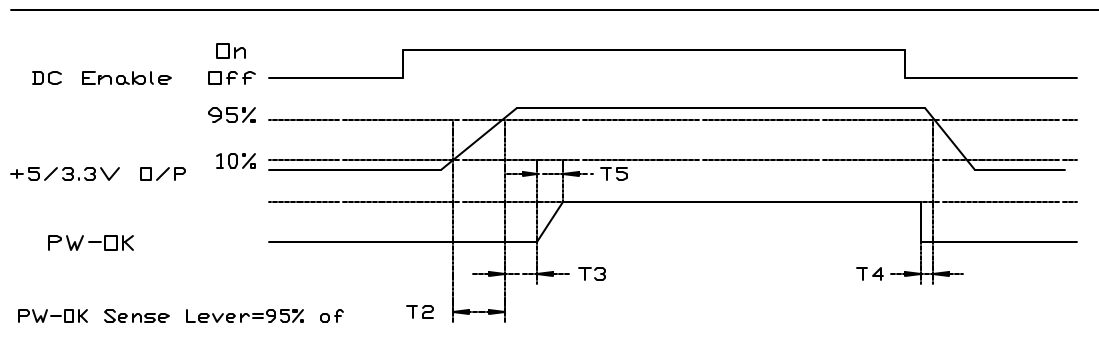

Although there is no requirement to meet specific timing parameters,

The following signal timings are recommended:

$$2\text{ms} < T2 < 200\text{ms}$$

$$100\text{ms} < T3 < 500\text{ms}$$

$$T4 \geq 1\text{ms}$$

$$T5 < 10\text{ms}$$

5) PROTECTIONS

- **OVER-VOLTAGE PROTECTION:** Standard on +5.0V output, set at $6.25\text{VDC} \pm 0.75\text{VDC}$.
- **SHORT CIRCUIT PROTECTION:** A short circuit placed between the DC Return and the output shall cause. No damage and the power supply shall shutdown.
- **OVER POWER PROTECTION:** The power supply shall shut down when output power exceeds 130% to 160% of full load and require a power on cycle be performed by the operate.
- **NO LOAD OPERATION:** No parts shall be damaged on the power supply.

6) ENVIRONMENT:

Operating Temperature

0°C to 50°C

Storage Temperature

-20°C to +70°C

Humidity

5 to 90% non-condensing.

Cooling

By forced air



ETA-USA

HIGH QUALITY SWITCHING POWER SUPPLIES

7) **RELIABILITY**

- MTBF OF POWER SUPPLY ELECTRONIS: 100,000 hours at full load and 25°C ambient temperature
- LIFE EXPECTANCY OF FAN: 40,000 hours at 40°C

8) **SAFETY REQUIREMENTS**

UL 1950 QQQQ2
UL 1950 QQQQ8
TUV Rheinland (EN60950, IEC950 mod)
CB Certification

9) **EMI/RFI**

FCC part 15, Subpart B, Class B
EN55022 CISPR22 Class B, CE Make
EN61000-3-3;1995
EN61000-4-2, -3, -4, -5, -6, -8, -11

10) **INSTRUCTIONS**

The set still works properly even if either unit is removed. The removed unit can't be used in other machinery nor for other purpose. When one unit breaks down, it's LED will blink, buzzer will sound. Push the Reset button and buzzer will stop.

REDUNDANCY Offer redundant function for power system and mutually backs up the outputs. A zero transfer time when backup takes place.

HOT-SWAP The power system provides a Hot-Swap function. This means when either one of the redundant power supplies fails or breaks down, you can easily replace failed unit without any interference to the system.

BUZZER A warning buzzer sounds when any one of the power supplies fails. The warning buzzer is resettable from reset switch either the one in front control panel or the one on the rear side.

LED'S The warning LED'S can be found either on the rear side or the control panel of the power system. Tells if one of the two power supplies has failed, by LED blinking.

HOT-PLUGGABLE The power system provides a Hot-Pluggable function. This method allows the power units in the Disk Array/File Server to be removed or inserted very easily without

11) **HOT-SWAP PROCEDURES**

Please refer to the followings when either one power supply unit is found defective.

- Locate** the defective power supply by examining the individual LED on the power unit or the LED on the front control panel if LED is Blinking.
- Unlock & Remove** the defective power supply unit.
- Replace** a new GOOD power supply unit, Insert the power supply into the power system chassis in position & it will auto Lock-up.
- Turn on** the new power supply unit.
- Check** the module LED which indicate the power and LED of total power system status, Both LED shall Have steady life.

12) DIMENSION: L 200 × W150 × H 86 mm

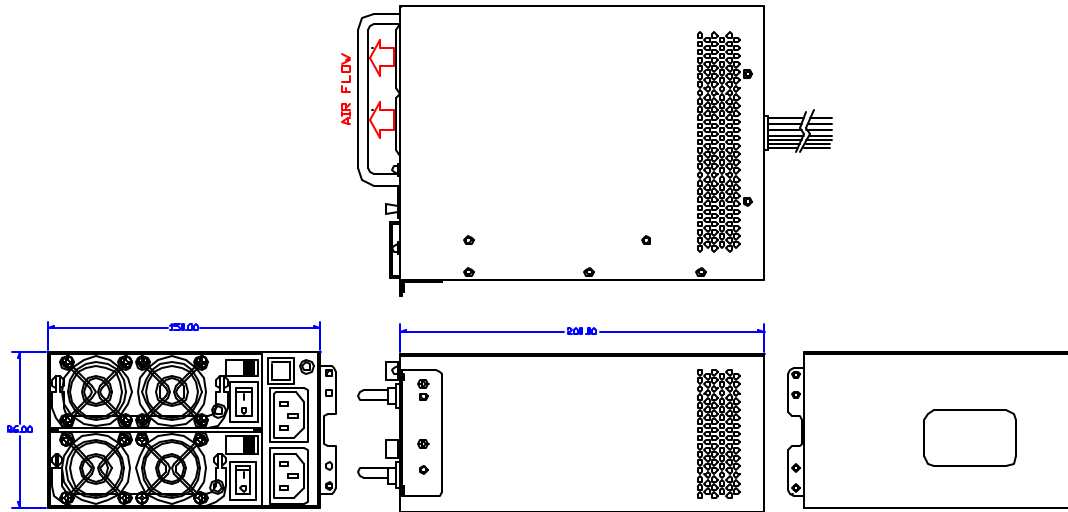

13) PINOUTS OF CONNECTORS

10 × 5.25", 2 × 3.5", 1 × ATX-24Pin (for motherboard), 1 × 8Pin Power Connector
1 × +12V Power Connector

Color Reference for LED cable

POWER#1 LED Cable	Brown / with
POWER#2 LED Cable	Red / with
MAIN POWER LED Cable	Green / with

