

### GENERAL SPECIFICATION

- UL / cUL / TUV / CE
- UNIVERSAL INPUT 90~265VAC
- HIGH EFFICIENCY UP TO 77%
- SHORT CIRCUIT PROTECTION
- INTERNAL INPUT FILTER



*Spring Type*



*Screw Type*

### 1) INPUT

Description	Min.	Max.	Condition
Rated input Voltage(VAC)	100	240	Io nom
Input voltage range			
AC IN(VAC)	90	265	Io nom
DC IN(VDC)	120	370	
Line frequency(Hz)	47	63	Vi nom, Io nom
Inrush current(A)			
Vi :115VAC		10	Io nom
Vi : 230VAC		18	

### 2) OUTPUT

MODEL NO.		OUTPUT VOLTAGE	OUTPUT CURRENT	EFFICIENCY (typ.)
Spring Type	Screw Type			
DIN18-05SX-CF	DINA18-05SX-CF	+5VDC	3000mA	73~75%
DIN18-12SX-CF	DINA18-12SX-CF	+12VDC	1500mA	75~77%
DIN18-15SX-CF	DINA18-15SX-CF	+15VDC	1200mA	75~77%
DIN18-24SX-CF	DINA18-24SX-CF	+24VDC	750mA	75~77%

**Hold up time:**(Io nom)

Vi=115 VAC

20mS, min.

Vi=230VAC

75mS, min.

**Output voltage accuracy** (Vi nom, Io min~Io nom)

**±1% max.**

**Voltage trim range:**(Vo nom,Io nom)

5V...15V models

-10%min / +15%max.

24V model

-10%min / +20%max.

**Minimum load:**(Vi nom)

0% min.

**Line regulation** (Io nom, Vi min ...Vi max)

**±1% max.**

**Load regulation** :(Vi nom, Io min ...Io nom)

**±2% max.**

<b>Transient recovery time:</b> (typ.50%load, step changed)		300 $\mu$ S typ.
<b>Ripple and noise:</b> (Vi nom, Io nom,BW = 20MHz)		50mV max.
<b>Temperature coefficient:</b> (Vi nom, Io min)		$\pm$ 0.02%/ $^{\circ}$ C
<b>Switching frequency:</b> (typ. Vi nom, Io nom)		100kHz, min.
<b>DC ON indicator threshold at start up:</b> (Vo nom, Io nom)	5V model	4.5VDC min.
	12V model	10.8VDC min.
	15V model	13.5VDC min.
	24V model	21.6VDC min.
<b>DC LOW indicator threshold at start up:</b> (Vo nom, Io nom)	5V model	3.75VDC min. / 4.5VDC max.
	12V model	9VDC min. / 10.8VDC max.
	15V model	11.25VDC min. / 13.5VDC max.
	24V model	18VDC min. / 21.6VDC max.
<b>Isolation voltage(Input/Output)</b>		3000VAC, min.
<b>Isolation resistance:</b> (Input / Output @ 500VDC,min.)		100M $\Omega$ ,min.

### 3) ENVIRONMENT (Operating at Vi nom, Io nom):

<i>Operating Temperature(70 to 100%)</i>	-10 $^{\circ}$ C to +50 $^{\circ}$ C
<i>Derating(+51 to +71<math>^{\circ}</math>C)</i>	2% / $^{\circ}$ C, max.
<i>Storage Temperature</i>	-25 $^{\circ}$ C to +85 $^{\circ}$ C
<i>Relative humidity</i>	20~ 95 % R H
<i>Cooling</i>	Free-air convection
<i>MTBF</i>	According to MIL-HDBK-217F, GF40 195,000 Hrs, typ.

### 4) MECHANICAL DRAWING

Case Material.....	Plastic
Dimensions.....	L90 x W22.5 x D115

### 5) CONTROL AND PROTECTION

Input fuse	T2A / 250VAC internal
Rated over load protection(Vi nom):	110% ~ 135%
Over voltage protection(Vi nom, Io nom):	125% ~ 145%
Output short circuit(Vi nom, Io nom)	Hiccup mode

### 6) APPROVAL AND STANDARDS

UL / cUL	UL508 / UL1310 Listed, Class 2 Power Supply
TUV	EN60950
CE	EN50081-1 / EN55022 for EMI
	EN50082-1 / EN55024 for EMS
FCC	Class B



## 7) CIRCUIT SCHEMATIC

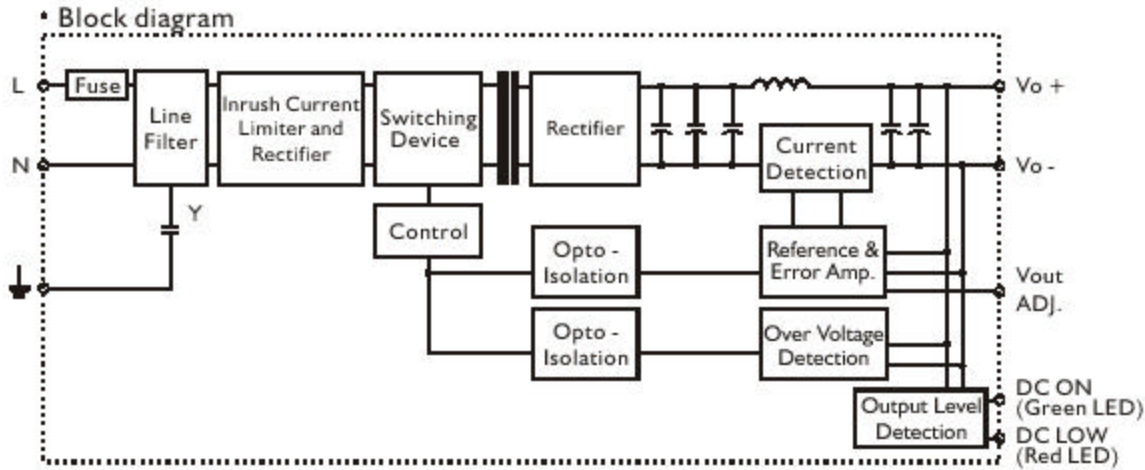

## 8) MECHANISM & PIN CONFIGURATION

### CONSTRUCTION

Easy snap-on mounting onto the DIN-Rail  
(TS35/7.5 or TS35/15), unit sits safely and  
firmly on the rail; tools required even to remove

### INSTALLATION

Ventilation / Cooling  
Normal convection  
Above/below 25m/m free space  
For cooling recommended  
Connector size range  
Solid: 0.2-2.0mm (AWG24-14)  
(use copper conductors only)

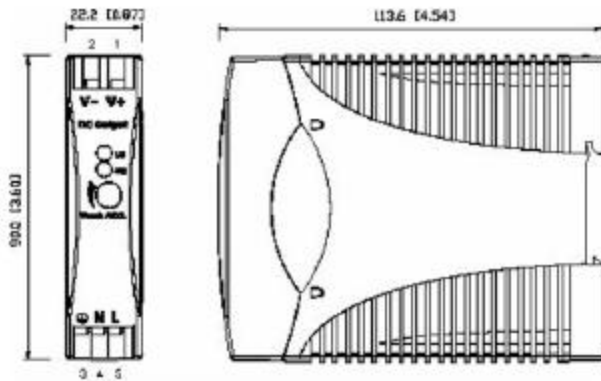

*Spring Type*

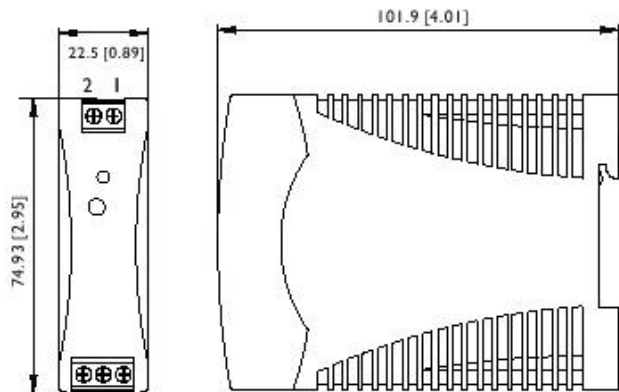

*Screw Type*

## 9) PHYSICAL CHARACTERISTICS

CASE SIZE..... 90 x 22.5 x 115 mm 3.6 x 0.89 x 4.53 inches  
 CASE MATERIAL..... Plastic  
 WEIGHT.....150 g

## 10) PIN ASSIGNMENT

PIN NO.		Designation	Description
1	OUT	V +	Positive output terminal
2		V -	Negative output terminal
3	IN	⏚	Ground this terminal to minimize high-frequency emissions
4		N	Input terminals (neutral conductor, no polarity at DC input)
5		L	Input terminals (phase conductor, no polarity at DC input)
	OTHER	ON	Operation indicator LED
		LO	DC LOW indicator LED
		Vout Adj.	Trimmer-potentiometer for Vout adjustment

## 11) DERATING CURVE

